

⚠ Si raccomanda dopo il montaggio e periodicamente di verificare il fissaggio. La Ditta non si assume alcuna responsabilità per eventuali danni riportati da persone o cose per un uso non corretto dei propri prodotti.

⚠ It is recommended after installation and periodically to check the fixing system. We are not responsible for damages to people and to things caused by wrong use or modifications of this product.

⚠ On recommande de contrôler la tenue des fixations après le montage et ensuite, périodiquement. Nous n'assumons pas la responsabilité pour dommages aux personnes ou choses provoqués par l'emploi erroné de nos produits.

⚠ Wir empfehlen, die Befestigung nach der Montage, sowie in regelmäßigen Zeitabständen zu überprüfen. Der Hersteller übernimmt keine Haftung für Personen- oder Sachschäden, die durch inkorrekte Anwendung seiner Produkte entstehen.

⚠ Después del montaje y de forma periódica se recomienda comprobar el anclaje. La empresa no asume responsabilidad alguna por posibles daños a personas o a cosas por un uso incorrecto del producto.

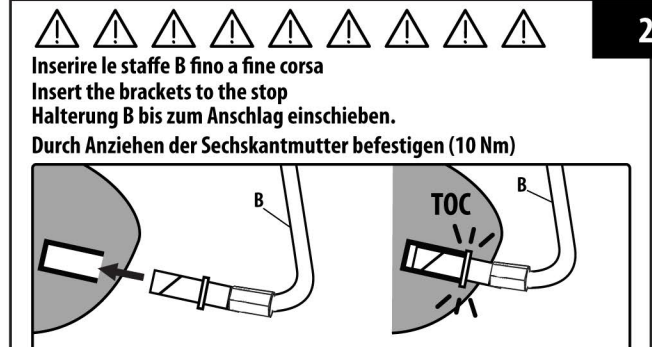
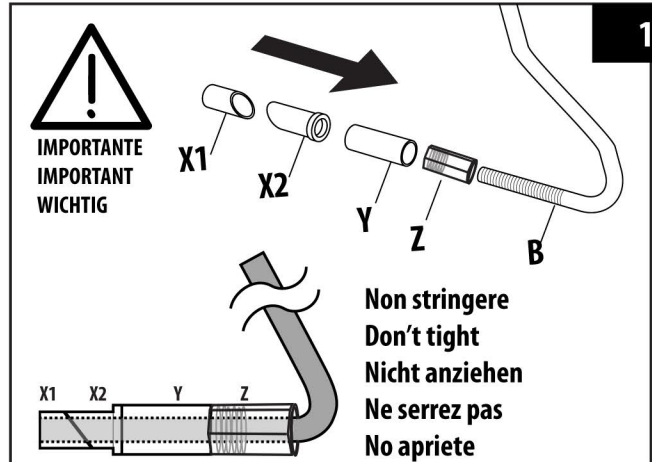

Stringere - Tighten - Anziehen - Serrer - Apretar

